

NEMA11 Hybrid Linear Stepper

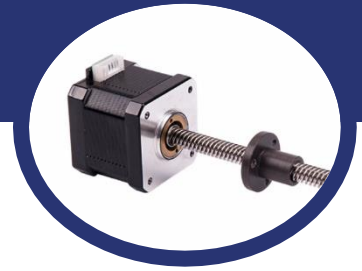

Key Features

- Small linear actuator solutions
- High performance and exceptional endurance
- Multiple screws and nuts can be selected

General Specifications

Part Number	Motor Length (mm)	Voltage (V)	Current (A)	Resistance (ohm)	Screw Length (mm)	Increment (mm/step)	Rated Thrust (N)
LSM111S-T6503-102-AR1-0	32	12/24	1	2.7	102	0,015	33

Optional Features

- Custom nuts
- Custom leadscrew

Mechanical Dimensions

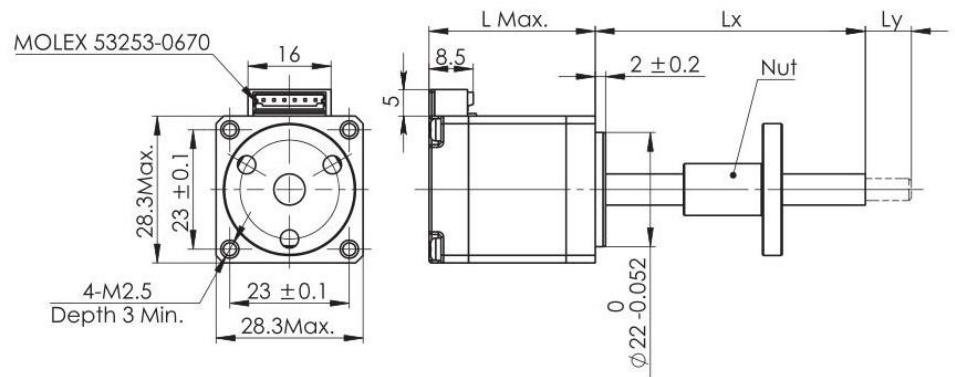

Motor Type	Dimension "L"
LSM111S	32 mm
LSM113S	41 mm
LSM115S	52 mm

Dynamic Force Curve

