

NEMA14 Hybrid Linear Stepper



Key Features

- Small linear actuator solutions
- High performance and exceptional endurance
- Multiple screws and nuts can be selected

General Specifications

Part Number	Motor Length (mm)	Voltage (V)	Current (A)	Resistance (ohm)	Screw Length (mm)	Increment (mm/step)	Rated Thrust (N)
LSM143S-T6503-102-AR1-0	36	12/24	2	1.61	102	0.015	85

Optional Features

- Custom nuts
- Custom leadscrew

Mechanical Dimensions

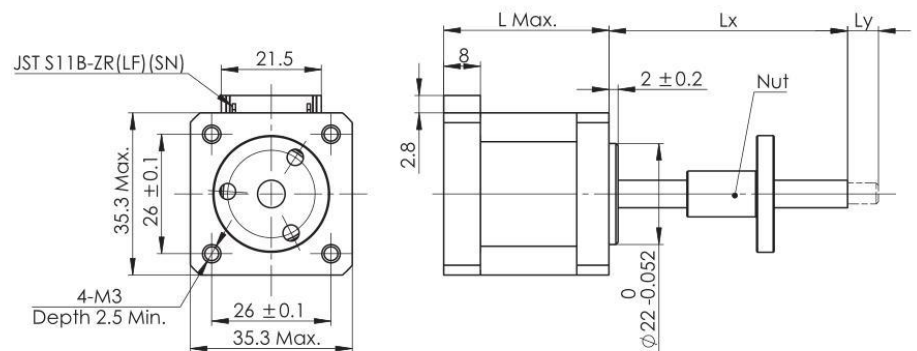

Motor Type	Dimension "L"
LSM141A	28 mm
LSM141S	28 mm
LSM143S	36 mm
LSM145S	55.5 mm

Dynamic Force Curve

